

Selective Bird Feeding: Deterring Nuisance Wildlife from Bird Feeders

Lisa Pennisi, Assistant Professor of Practice, School of Natural Resources
Stephen M. Vantassel, Project Coordinator — Wildlife Damage Management

Feeding birds is a fascinating activity and a wonderful way to connect families and children with nature. Attracting songbirds, for example, allows us to watch their behavior, listen to their songs and calls, appreciate their beauty, develop observation skills, and enjoy nature in our backyards.

Unfortunately, bird feeders often attract unwanted guests that can cause a great deal of expense by consuming seed, damaging feeders, and even invading your home. This Extension Circular offers practical solutions to attract the birds you want while keeping out squirrels (*Figure 1*), mice, rats, chipmunks, raccoons, deer, opossums, insects, and non-native and undesirable birds such as starlings, House Sparrows, and pigeons.

Strategies for Deterring Unwanted Wildlife

For best results, implement as many of the following strategies as possible, and continuously monitor for effectiveness. While these strategies are effective, some animals are more persistent and may require additional effort.



Photo by Elizabeth Walter-Shea.

Figure 1. Fox squirrels can scale shepherd's crook hangers.

Strategy #1: Choose the Best Location for Your Feeders

Selecting the right location for a feeder is critical to preventing unwanted animals from accessing food and damaging the feeder.

Squirrels, raccoons, and other animals can access feeders by climbing up trees and poles, running across wires, and leaping up, down, or horizontally from nearby perches. While feeders are designed to hang from trees, attach to deck rails, suction onto windows, or hang from a pole, those located on poles allow the most control over unwanted species.

Ideally, place feeders on poles at least 6 feet high and 8 feet away from the nearest branch, deck rail, or fence that an animal could use as a platform to jump to the feeder. To prevent ambush attacks from lay-and-wait predators such as house cats, make sure poles are 6 feet from plants or structures that could conceal predators. To prevent animals from climbing the pole, secure baffles (see Baffles below) at least 4 feet off the ground and just below the feeder. When hanging a feeder from a tree, hang it from branches that keep the feeder at least 6 feet above the ground and 6 feet away from the trunk and other branches. Hang the feeder from a branch using a hook or wire with a squirrel baffle above the feeder.

Strategy #2: Use Barriers

Baffles

Baffles are physical barriers that prevent squirrels and other climbing animals from reaching the feeder. They can be placed above, below, or both above and below the feeder. **Do not grease poles to prevent animals from climbing the poles. Greasing a pole is ineffective as the grease becomes tacky with time allowing for easier climbing. The grease also harms wildlife by matting fur and feathers and reducing insulation from inclement weather and hindering flight.**

Pole-mounted feeders need baffles placed above them if animals can jump onto the tops of the feeders. Pole-mounted squirrel baffles are either flat, dome shaped, or cylinders, and can be stationary or spring loaded. A baffle will need to be attached to the pole below the feeder to prevent squirrels and other animals from climbing up the pole (*Figure 2*). Baffles below pole-mounted feeders should be placed at least 4 feet above the ground. Locate the pole 7 to 8 feet from fences, decks, trees trunks, and overhead branches that squirrels can use as launching pads to reach the feeders.



Photo by Stephen M. Vantassel.

Figure 2. Tube baffle.

Stationary baffles need to be 14 to 18 inches long or wide to prevent animals from climbing over them. Spring-loaded pole baffles move up or down on the poles when an animal tries to climb over it. When these baffles are activated, they slide causing the animal to fall to the ground, and the baffle moves back into place. Either type needs to be constructed of smooth material, such as smooth metal, to prevent sharp claws from gripping the baffle, thus defeating the purpose.

Bird feeders suspended from tree branches and other overhead structures need baffles above the feeder to prevent animals from gaining access from above. A hanging feeder will not need baffles below if it is hanging free from structures that allow animals to reach it from below. Baffles hung above hanging feeders are either flat, shaped like domes (*Figure 3*), or like sloping cones much like a witch's hat (*Figure 4*). Sloped-cone baffles work best. The slope and length prevent squirrels from grabbing the hook with their back feet and stretching across the baffle to grab the feeder. When they try, they simply slide off the cone. Sloped-cone shaped baffles also deter squirrels from jumping onto the baffle to shake food out of the feeders.

Feeders hung on outstretched wire similar to a clothesline may be protected with tube baffles. Several short sections of PVC tube placed along the length of the line will serve as a deterrent. The PVC tubes will spin



Photo by Stephen M. Vantassel.

Figure 3. Baffle suspended above a hanging feeder.



Photo by Lisa Pennisi.

Figure 4: Sloped cone shaped baffle.

when a squirrel tries to cross the wire, causing the animal to fall off the line. Additional protection can be provided by placing spinning disks between the sections of PVC tubes. Two-foot diameter disks will block a squirrel's vision and force it to jump over the disk onto a spinning PVC tube, causing it to fall off the wire. Be sure to use wire that has a heavy enough gauge to support the weight of full feeders and baffles. Do not use rope or cord. Squirrels have been known to chew through these materials, dropping the feeder to the ground, to get to the seed. (A diagram of wire baffles can be found in NebGuide 1924, *Control of Tree Squirrel Damage*, www.ianrpubs.unl.edu/sendIt/g1924.pdf.)

Prevent squirrels from climbing poles or trees by securing a 3-foot wide (or greater) section of metal flashing around the pole or tree (Figure 5). For best results, place the bottom of the flashing 3 feet above the ground.

Flashing placed around a tree must not be too tight so, as the tree grows, it does not girdle and kill the tree. Cut the flashing longer than needed to allow for expansion, and place several plastic dowels or rods between the tree and the flashing to prevent injury and moisture buildup. This technique will only work on a tree that



Photo by Stephen M. Vantassel.

Figure 5. Flashing on a tree to prevents animals from climbing.

Table 1. Seed preferences for various song birds

	Millet	Corn	Safflower	Milo Sorghum	Thistle	Black Oil Sunflower	Striped Sunflower	Hulled Sunflower	Peanuts, in shell	Peanut, hearts	Suet
Northern Cardinal			P			P	✓	✓			
Blue Jay						✓	P		P	✓	P
Black-capped Chickadee						X	✓	P			P
Tufted Titmouse						P	✓	P			P
Nuthatches								P		✓	P
Woodpeckers								P		P	P
House Sparrows	P										
Song Sparrow	P										
White-throated Sparrow	P	P									
White-crowned Sparrow	P										
Common Grackle	✓	P				P	P	P		✓	
Brown-headed Cowbird	P					✓					
Mourning Dove	P					P					
American Goldfinch					P	✓	X	P			
Pine Siskin					P						
Purple Finch					P	✓	✓	P			
Grosbeaks			P			P					
Dark-eyed Junco	P			✓	✓	✓	✓	✓			

P=preferred

✓=will eat

Adapted from Geis, A. D. (1980). Relative Attractiveness of Different Foods at Wild Bird Feeders. Special Scientific Report No. 233, U.S. Dept. of Interior, Fish and Wildlife Service. Washington, D.C.

does not have branches from other trees, bushes, fences, or roofs nearby that animals can launch from to reach the tree.

nals prefer sunflower and safflower seed and will sweep out millet, which is preferred by sparrows. Conversely, sparrows will sweep out sunflower to get to the millet (*Table 1*).

Strategy #3: Minimize Fallen Seed

Many birds scatter seed as they feed. This covers the area below a feeder in seed or seed hulls, which is sure to attract squirrels, mice, rats, voles, or other rodents found in your area. Seed scattering occurs for several reasons:

- Whole birdseed requires birds to remove and discard the shells or hulls to get to the meat or kernel just like when you eat sunflower seeds.
- Inferior seed mixes that contain filler seeds, such as wheat, and assorted grain products that birds do not eat. These are ejected to the ground thereby attracting rodents and other unwanted animals to feed.
- Mixed seed forces birds to “sweep” through the mix to select preferred seeds. For example, cardi-

The following sections discuss how to eliminate or substantially reduce these problems.

Catch Seed Before It Hits the Ground

To prevent seed from falling onto the ground, feeders often come with trays to catch seed that birds scatter while feeding. Trays also can be added below feeders and above baffles (*Figure 6*). However, in addition to catching seeds and hulls, trays also catch bird droppings and can allow mold to grow or attract insects. Therefore, clean the trays of feeders actively used in the winter at least weekly. Clean all feeders weekly in the summer, when mold is more likely to grow. Trays with drainage holes will help prevent water buildup and mold growth. Trays made of mosquito-wire screen will allow optimal drainage and require less cleaning, providing a more sanitary and disease free feeding station.



Photo by Stephen M. Vantassel.

Figure 6. Note the converted metal trash can lid used as a seed catcher.

Selectively Purchase Seed

Another option for minimizing seed and hull spillage is to adjust the type of seed you are using. Seed mixes typically consist of a variety of seed including corn and millet mixed in with sunflower seeds. While corn and millet attract some species, other birds routinely toss it aside to get at the more desirable sunflower seeds. Consider buying one feeder for each type of seed. Purchase feeders and seed based on the species you want to attract (*Table 1*). For example, if you wish to attract cardinals, fill the feeders with sunflower seeds, thus reducing selective scattering of seed, which will deter less desirable species.

Even sunflower seeds will lead to some waste as birds drop seeds when cracking the shell, and the resulting hulls will be scattered on the ground. To really deter waste, hulled sunflowers, either whole or chipped, can be purchased. While this seed may be more expensive, you are not purchasing the hulls. Hulled sunflower is ideal for use in small tube and satellite feeders that attract small birds such as chickadees, nuthatches, titmice, and finches. It also can be used in platform and hopper feeders. Minimizing waste will save time filling feeders as feeders will be full longer. In addition, this should decrease the need to catch rodents that are attracted to the seed and then

stay nearby, perhaps finding a warm place to nest in your house.

Adding Repellents to Food

Repellents added to food affect scents and tastes. Taste repellents include hot peppers and hot sauce. All mammals, including humans, have brain receptors that sense the burning sensation that occurs when eating peppers. And it is just that — a sensation, which causes no harm. Conversely, birds lack those receptors as well as a sense of taste. Birds find food predominately by sight and will not be deterred by hot peppers; in fact, birds will eat whole peppers. Squirrels and other mammals will be deterred by hot peppers when other food is available. In winter, when food is scarce, this will not always be effective. Spicing feed needs to be done so that the capsicum in the peppers cannot get into the animal's eyes and cause discomfort. Squirrels and other mammals have been known to damage their eyes from frantically rubbing in effort to remove the sting. You can buy suet cakes and seed mixes that have the peppers mixed in already.

There are a number of scent repellents on the market. Scent repellents are not effective on pest bird species. Theoretically they work better on mammals, but they do not work very well on mammals, even those that rely on a keen sense of smell.

We do not recommend using repellents. Hungry animals will have high tolerance of the repellent if the alternative is starvation. Proper placement of feeders and using physical barriers work better than taste and smell repellents when trying to manage a bird feeding station.

Strategy #4: Choose A Bird Feeder

Several types of feeders are designed to impede squirrel access or damage and are known as being squirrel resistant or squirrel proof. Specialty feeders are designed to either feed certain species, such as hummingbird feeders and clinging bird feeders, or are designed to hold a specific type of seed such as thistle. Because these feeders focus on a single species or seed variety, they reduce the amount of seed reaching the ground and help attract the species you want. *Table 2* provides more information on the seed and feeder to use to attract certain species.

Table 2. Recommended feeders and food to attract specific bird species

Bird Species	Food to attract species	Feeders									
		Tube (thistle); thistle sock	Tube, small holes; caged tube	Satellite	Clinging suet	Suet	Peanut	Weighted hopper	Platform	Ground	Other
American Goldfinch	Thistle, sunflower hearts	✓									
Black-capped Chickadee	Sunflower hearts, suet		✓	✓	✓						
Blue Jay	Peanuts, striped sunflower						✓	✓	✓		Weighted hopper will allow for grackles and starlings
Brown Creeper	Suet, peanut butter, peanut hearts, insects					✓	✓				Bark crevices
Dark-eyed Junco	White millet, cracked corn, sunflower hearts, peanuts, insects								✓	✓	Ground spread in protect areas
Downy Woodpeckers	Suet, insects, peanuts, hulled sunflowers, peanut butter		✓		✓	✓	✓				
Grosbeaks	Black oil sunflower, safflower		✓					✓	✓		
Hairy Woodpecker	Suet, insects, peanuts, hulled sunflowers, peanut butter		✓		✓		✓				
House Finch	Thistle, sunflower hearts	✓									
Mourning Dove	White millet, black oil sunflower							✓	✓		Weighted hopper will allow for grackles and starlings
Northern Cardinal	Black oil sunflower, safflower or sunflower hearts							✓	✓		
Northern Flickers	Suet, peanuts, hulled sunflower, insects, nut meats, raisons, fruit slices		✓		✓		✓				
Pine Siskin	Thistle, sunflower hearts	✓									
Red-bellied Woodpeckers	Suet, peanuts, hulled sunflower, insects, nut meats, raisons, fruit slices		✓		✓		✓				
Red-breasted Nuthatch	Sunflower hearts, suet peanut butter		✓	✓	✓						Logs for peanut butter
Song Sparrow	White millet, sunflower		✓						✓	✓	Ground spread in protected area
Tufted Titmouse	Sunflower hearts, suet		✓	✓	✓						
White-breasted Nuthatch	Sunflower hearts, suet peanut butter		✓	✓			✓				Logs for peanut butter
White-crowned Sparrow	White millet, corn, sunflower hearts		✓						✓	✓	Ground spread in protected area
White-throated Sparrow,	White millet, corn, sunflower hearts										Ground spread in protected area

Squirrel Resistant Versus Squirrel Proof Bird Feeders

Squirrel resistant bird feeders are resistant to squirrel damage but squirrels can still get food out of them. Most squirrel resistant feeders are made from heavy wire mesh or metal, but they can still be damaged if a squirrel or raccoon knocks them down.

Squirrel proof feeders prevent squirrels from accessing the birdseed. Squirrel proof feeders include weighted hoppers, caged feeders, and feeders with built-in baffles. Both squirrel resistant and squirrel proof feeders can be heavy, especially when full of seed. Therefore, be sure the spot where you want to hang them can securely hold the weight. Also be sure it is not too heavy for either an extension pole (if using a pole to hang feeders at a distance) or for the person hanging the feeder.

Weighted Feeders

Weighted feeders are designed to keep undesired mammals and birds out by using weights or springs. The seed opening on these feeders will shut when heavy birds or mammals stand on the perch to gain access to the seed (Figure 7). Weighted feeders may be factory set or may be adjustable. If adjustable, the sensitivity of the feeder can be set to keep out larger birds such as common grackles and blue jays while allowing access to cardinals and smaller birds such as chickadees. With proper placement and the use of baffles, some squirrel proof hopper feeders are very effective. Without baffles and good placement, determined squirrels have been known to outwit



Photo by Stephen M. Vantassel.

Figure 7. Gravity-close feeder.



Photo by Stephen M. Vantassel.

Figure 8. Caged feeder.

this type of feeder by hanging upside down from the top to avoid the weighted perch and throwing feed out of the hopper onto the ground. In addition to baffles we recommend a seed tray and using a single seed or high-quality mix targeted to the species you want to attract.

Caged Feeders

Caged feeders are seed feeders and suet baskets encased with a sturdy wire cage denying access to squirrels (Figure 8). The 1/4 inch openings allow small birds such as chickadees, nuthatches, and Downy Woodpeckers to enter. Larger woodpeckers, such as the Red-Bellied Woodpecker and Northern Flickers, reach through the cage with their long tongue to extract seeds. These feeders will also prevent Common Grackles and European Starling from reaching the seed.

The most common caged bird feeders are seed tube feeders, nyjer (thistle) seed feeders, peanut feeders, and suet feeders. Quality feeders of this type can be hung from tree branches or mounted on sturdy poles with no additional protection. Hang them securely to prevent squirrels and raccoons from knocking them to the ground. Quality caged feeders made of sturdy materials may be heavy when filled with seed and may not be good choices if hanging high up in trees or on lightweight poles. The weight can also strain and bend extension poles used to hang the feeders.

Platform Feeders

Platform feeders attract a variety of both large and small birds, including birds that feed primarily on the ground such as doves and juncos. Platform feeders offer a number of advantages:

- they get ground feeders up and away from potential predators such as cats,
- you can put a feeder in a line of sight so you can enjoy seeding the birds,
- they are easy to clean and maintain,
- they can accommodate a number of birds at one time.

These feeders can be hung or mounted on poles. Select one with a screen or perforated metal bottom which will prevent water from accumulating in the feeder and help to air dry seed after rains. Some have a roof to protect feed and birds from inclement weather. With this type of feeder, birds are easily able to select the seed product they prefer so tossing seed is greatly reduced. You can use black oil sunflower seed, safflower seed, nuts, seed mixes, peanuts in the shell, or even mealworms or fruits. Platforms need to be protected from squirrels by using baffles placed both above and below the feeder, depending on placement as described above.

Tube Feeders for Finches and Other Small Birds

Tube-shaped feeders are designed for small birds such as chickadees, titmice, and finches. These feeders have small perches to deter larger birds such as grackles and starlings who need more room to comfortably perch, although woodpeckers may still be able to cling to the small perches (*Figure 9*). While tube feeders have small perches that deter larger birds, House Sparrows can still use the perches. If House Sparrows become a problem, reduce the length of the perches to 5/8 inch, which should exclude them and still allow finches, chickadees, and siskins to perch.

The seed ports, or access holes, on tube feeders vary in size from very small for nyjer thistle to large enough for safflower and sunflower seed. If used with hulled sunflower hearts or thistle, there will not be much waste associated with these feeders. When used with whole sunflower or safflower, a seed tray can be added to reduce ground spillage. The tray also will allow cardinals and other birds to feed which, depending on the species you are trying to attract or avoid, may or may not be desirable. Squirrels tend to leave nyjer and safflower alone, and feeders filled with these seeds may not need squirrel baffles. However, squirrels have been known to chew the seed ports on these feeders to get at sunflower seed. Sturdy feeders made from polycarbonate tubes with metal seed ports are available and make it difficult for squirrels to chew. Nevertheless, to really deter squirrels, a sloped cone-shaped baffle above the feeder is necessary when hanging the feeder in a tree. If the feeder is mounted on a pole or shepherd's hook, a squirrel baffle mounted on



Photo by Stephen M. Vantassel.

Figure 9. Tube feeders including a peanut feeder in the center.

the pole below the feeder will help prevent squirrels from climbing the pole to reach the feeder.

Tube feeders designed for nyjer thistle seed are used to attract members of the finch family. Thistle-eating species include goldfinches, Purple Finches, House Finches, and Pine Siskins. Finch seed mixes that include sunflower hearts are also sold. Mixes containing sunflower seeds will also attract woodpeckers, chickadees, nuthatches, and other small birds. A good finch mix contains only fine sunflower chips and nyjer seed. Avoid commercial finch mixes that contain millet, canary grass seed, and other fillers that are rejected by finches, leading to scattered food on the ground. Make sure thistle seed is fresh as it has a short shelf life and birds will reject old seed. The short shelf life is due to heat sterilization. The seed is sterilized because it is from India and is not a North American thistle. The sterilization is done to prevent introduction of a non-native species. Nyjer seed is actually not a North American thistle; it is imported from India and Ethiopia and is sterilized with heat to avoid the accidental introduction of non-native plants. This sterilization process creates a short shelf life and finches will reject old nyjer seed.

Satellite or Clinging Bird Feeders

Small satellite feeders do not have perches, but small birds such as chickadees, titmice, and nuthatches have no

trouble clinging to the side to get the seed. Globe satellite feeders also allow small birds to fly inside to access food. This design limits access by large birds. These types of feeders can be surrounded by cages that only allow small birds to fly through the cage openings to access food. If located properly, these feeders will not need a baffle above or below. Sunflower hearts are recommended for these feeders.

Suet Feeders

Suet is made from rendered beef or mutton tallow. It is used primarily to attract birds that hunt insects along the tree trunk. Birds attracted to suet include woodpeckers, chickadees, cardinals, titmice, wrens, and nuthatches. Unfortunately, grackles, starlings, squirrels, and raccoons are very attracted to suet too. Much like other feeders, suet feeders require placement far enough from tree trunks and branches, or the use of a baffle to deter squirrels and other unwanted species. Upside down suet feeders, where the suet is only exposed from underneath, allows clinging birds to feed while excluding starlings, grackles, and other unwanted birds. Suet feeders enclosed in a cage resists access from starlings as well as squirrels.

Suet can also come with capsicum, which will deter squirrels; however, we do not recommend using deterrents such as capsaicin, which will not harm or deter birds, but can hurt mammals if it gets in their eyes.

Hummingbird Feeders

It is best to attract hummingbirds with flowers rather than feeders because the birds receive better nutrition from flower nectar. Hummingbird feeders provide a source of artificial nectar which provides energy in the form of carbohydrates. Since hummingbirds obtain their protein from insects such as spiders, gnats, and aphids found on the flowers, avoid using pesticides on or around your flower garden. Flowers that attract hummingbirds are tubular flowers rich in nectar and in shades of bright red or orange. Examples of attractive hummingbird flowers include trumpet honeysuckle (*Lonicera sempervirens*), trumpet creeper (*Campsis radicans*), pentas (*Pentas lanceolata*), salvia (*Salvia* sp.), and cuphea (*Cuphea* sp.).

If you choose to use hummingbird feeders, you can use a home recipe or a commercial mix. Commercial nectars made from fructose should be changed weekly. Home recipes containing refined sugar should be changed at least every other day to prevent harmful bacteria and mold from developing. Never add any dyes or coloring to the nectar; these are unhealthy for the birds. Avoid placing feeders in direct sunlight as the heat will separate the sugars and can cause the nectar to spoil.

Hummingbird feeders can attract ants and bees. To block ants from invading the feeder, use an ant moat attached above or below the feeder. Moats are filled with water to block ants from crossing. Some feeders come with ant moats. To keep bees away, purchase dripless feeders that do not have yellow plastic flowers. If the dripless feeder has yellow, paint red over the yellow — bees are attracted to yellow and hummingbirds are attracted to red. Hummingbirds can be very territorial, fiercely defending a feeder from other hummingbirds. If you have a territorial hummingbird, one solution is to put up a second feeder out of sight of the first.

Strategy 5: Control for Pest Species

Control of Unwanted Birds

Non-native birds such as European Starlings, pigeons, and House Sparrows are often considered pests at bird feeders. Flocks of starlings can empty a feeder in just a few hours, upping your bird seed bill considerably. Feeders that deter squirrels, such as caged feeders and weighted feeders, can deter these larger birds too. Tube feeders with small perches do not offer enough room for a large bird to perch. Additionally, many of these large birds do not like to cling upside down or to land on unstable small perches. Therefore, small feeders that require clinging will help deter these larger birds. The Magic Halo (*Figure 10*) was invented by University of Nebraska–Lincoln Professor Dr. Ron Johnson, Emeritus, who discovered that House Sparrows do not like objects above their head. The 30-inch wire hoop will deter up to 86 percent of House Sparrows from approaching the feeder. With monofilament lines or thin wires draped from the wire hoop, the rate increases to 99 percent reduction of House Sparrows. See NebGuide G2024, *Urban Pest Birds: Controlling Damage* (www.ianrpubs.unl.edu/sendIt/g2024.pdf) for more information.

Change Bird Feed

Using less mixed seed in your feeders can deter pest birds. Starlings and grackles prefer corn and soft millet seeds that often form the bulk of seed mixes. All bird seed is required by law to list seeds in order by volume. Read the label to avoid inferior mixes containing corn, wheat, red millet, and other filler seeds that birds do not eat. A seed with a hard shell, such as striped sunflower and safflower, often deters starlings and grackles. Safflower seed will attract most of the common backyard feeder birds such as chickadees, house finch, cardinals, and nuthatches. Grackles, starlings, House Sparrows, and squirrels usually avoid safflower, but this may not always

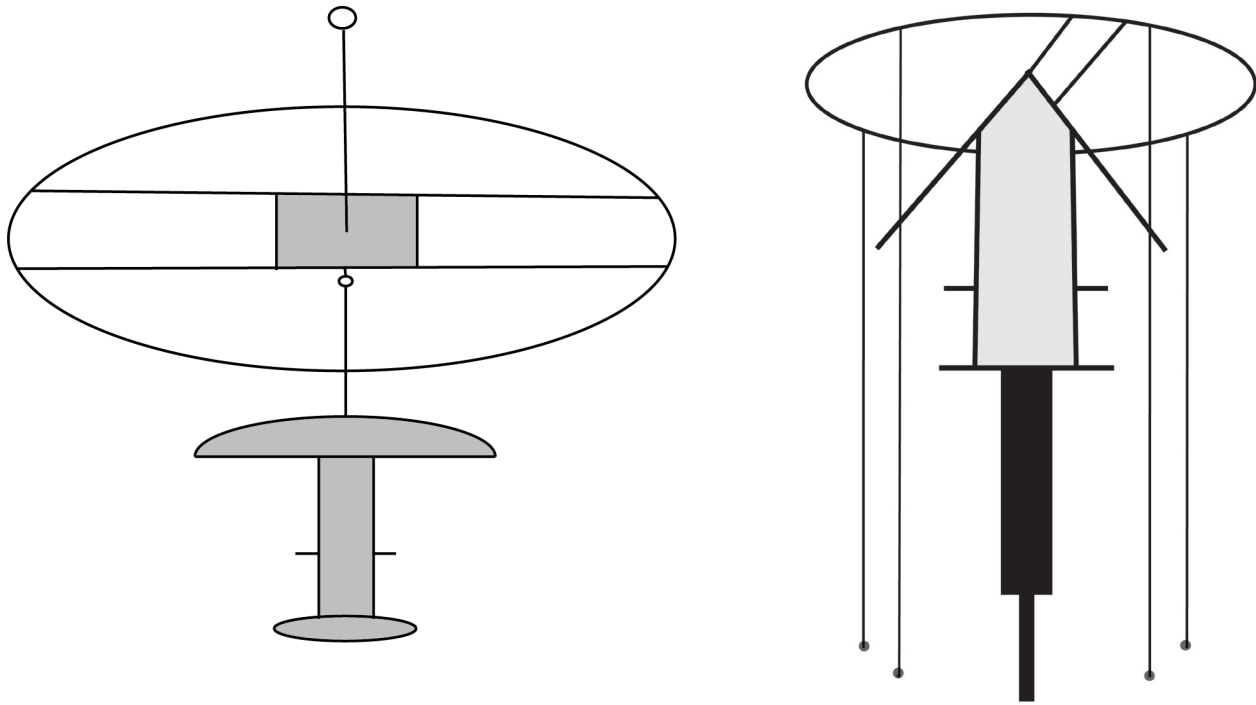

Illustrations by Stephen M. Vantassel.

Figure 10. The Sparrow-Free Magic Halo’s effectiveness can be enhanced by hanging weighted lines down from the halo (as shown). The lines may also be connected to the ground.

be the case. Regular safflower seed can be messy since the hulls accumulate under the feeder. Hulled and thin-hulled safflower, such as NutraSaff™ (Golden Safflower), which is said to reduce waste and be preferred by birds over traditional safflower seed, is available.

Starlings, on the other hand, may be more difficult to deter from bird feeders. First and foremost never feed popped corn, cereals, pastry products, bread, and food scraps. These foods are a magnet for the starlings and can attract large flocks. Caged bird feeders, upside down feeders and specialty clinging feeders, and feeders with small perches will help thwart unwanted starlings that cannot cling upside or to small perches.

Birds of Prey (Raptors)

Some hawks prey on smaller birds. Raptors in the Accipiter family such as Cooper’s hawks and sharp-shinned hawks are adapted to flying through dense vegetation to ambush prey birds. The larger of the two, the Cooper’s hawk, can feed on larger birds such as robins, blue jays, pigeons, doves, and starlings. The Sharp-shinned (“Sharpie”) Hawk is about the size of a blue jay and preys on smaller birds such as sparrows, juncos, and titmice, although a large female Sharpie (females are larger than males), may hunt larger birds.

Bird feeders provide great hunting ground for these raptors that will perch nearby and then swoop in to catch a bird. Both hawks are native, and other birds are their natural prey; therefore, this is part of the cycle of life. Since only 10 percent of hawk predation attempts are successful, you are providing an opportunity to help hawks and the natural order of things. Many bird enthusiasts consider themselves lucky to witness this natural predator-prey behavior. However, if you want to protect the songbirds at your feeders from hawks, here are some precautions you can take:

- Avoid ground feeding.
- Strategically place feeders 10 feet from dense shrubbery. This is close enough to provide birds cover but far enough away to prevent ambush of birds by cats.
- Provide fewer vantage points for perching. If fencing is serving as a perch, a thin wire along the top will discourage perching.
- Hang feeders close to obstructions such as under the eaves of the house or an awning.
- Use caged and hanging feeders, which allow for fewer hawk strikes than platform and hopper feeders.
- Stop feeding for a week or two so the hawk finds a new hunting ground.

Control for Non-Avian Species

Brush Piles

Brush piles are a great way to compost branches and twigs, and these piles also provide habitat for wildlife. Small, loose piles of branches provide sanctuary from small birds hiding from predators. If providing wildlife cover is desired, that is a bonus, just keep the pile away from the house. If not, consider getting rid of brush piles to deter rodents, opossums, and raccoons from making homes in them. Or try keeping the piles small and loose, as large dense piles will be used more by mammals than birds.

Pet Food and Water

Pet food is an attractive meal to many wildlife species. Raccoons, skunks, opossums, rats, mice, turkeys, and some songbirds will eat unattended pet food. Allow your pet 10 to 30 minutes to eat, then pick up the dish. If this is not possible, definitely pick up the dish before the sun sets to deter nocturnal mammals. This practice not only deters pest species, it lessens the likelihood of your pet being exposed to parasites and diseases from wildlife.

Squirrels

Watching squirrels jump onto feeders, sit up to eat, hang upside down, run across your deck, chase each other around the trees, and try various ways to get at your feeders can be amusing. But squirrels can cause considerable damage to your seed budget, your feeders, and your property. Several options are available such as placing feeders strategically, using squirrel baffles, using squirrel resistant feeders or deterrents, and purposely feeding squirrels at a squirrel feeding station.

Some suggest using dedicated squirrel feeders so there will be no need for the squirrels to bother the bird feeders. Unfortunately, feeding squirrels at squirrel feeding stations may provide a temporary solution, but often the result is more squirrels visiting your yard. In addition, well-fed squirrels have larger litters and/or higher survival rates, resulting in even more squirrels needing food and shelter in the future.

A variety of squirrel feeders are available; some are even designed to encourage squirrel antics such as spinning ears of corn, sitting upright in chairs, and climbing in glass jars, providing entertainment value. If you decide to use squirrel stations, position them 10 to 15 feet or more from bird feeding stations and use food that squirrels find particularly attractive such as corn, peanuts, walnuts, and other nuts. Feeders designed for squirrels

need to be of sturdy construction and material such as thick hardwood or metal. Since squirrels are tenacious, many squirrel feeding enthusiasts find ways to challenge their problem-solving abilities.

If you choose to set up a squirrel feeding station keep the following potential problems in mind:

- You must keep the squirrel feeders well stocked so squirrels won't turn to the bird feeders — give them an inch and they'll take a mile. Therefore, a dedicated squirrel feeder may not be effective at keeping the squirrels from the bird feeders at all; it may just attract more squirrels.
- Squirrels often cache food or scatter hoard — bury it for later use in lean winter times or even for tomorrow. Be prepared to have your flower beds, flower pots, and lawn dug up as squirrels bury their treasure,
- Squirrels also can be territorial and mark territory with scent or by chewing. While chewing trees, decks, and roofing keeps their teeth sharp and marks territory, it can cause considerable damage.
- As squirrel numbers increase, squirrels may seek shelter in your attic. Once in your attic, squirrels can cause a lot of damage such as chewing electrical lines. To decrease the chance of this kind of damage, keep trees trimmed so squirrels cannot jump on the roof. Also, keep feeders away from the deck. See NebGuide G1924, *Control of Tree Squirrel Damage* (www.ianrpubs.unl.edu/sendIt/g1924.pdf), for more information.
- If you decide to stop feeding squirrels and/or other mammals, do so gradually. A gradual reduction in supply over two weeks will allow the animals time to adjust. A sudden loss of feed can lead to property damage as animals search for food. The more visiting animals you have at your feeders, the longer you should stretch the reduction in food. You should also stretch the reduction time to more than two weeks if it is winter or breeding season.

Raccoons

Although raccoons are exceptional climbers for their size, baffles (8 inches in diameter or larger) are effective in preventing them from gaining access to pole feeders. Raccoons are unable to traverse wires so a feeder hung along a wire will be safe provided they cannot jump on it from above. However, raccoons may shake food out of the feeder. One of the simplest ways to stop raiding is to break their feeding cycle by removing seed for a week or so. See NebGuide G1688, *Controlling Raccoon and Opossum Damage* (www.ianrpubs.unl.edu/sendIt/g1688.pdf) for more information.

Ground-Feeding Mammals — Mice, Voles, Opossums, and Skunks

Reducing the amount of seed reaching the ground discourages large numbers of rodents and reduces the attractiveness of the site to opossums and skunks. If conflicts with these species become intolerable, empty all bird feeders and initiate control measures. (Publications containing information on how to control specific pests are listed in the Resources section.)

Properly storing seed and suet is extremely important for managing potential rodent and bug pests. Seed should be secured in steel or heavy plastic containers with secure lids. If you store the food outside, it is essential to make sure the containers are made of a sturdy material such as metal that cannot be chewed through by rodents. Insects, including ants, moths, and carpet beetles can also infest your seed, so the storage vessel should also be air tight. When filling feeders, be careful not to spill seed next to the house to avoid attracting rodents.

Deer

Deer are attracted to many types of birdseed. To deter deer, feeders should be at least 6 feet high. Deer will use their tongue to get seed but they may also butt the feeder or pole to knock seed out. If butting is a problem, install a rigid wire fence (2 by 2 inch weave) at least 3 feet away from the pole and at least 4 feet high. Another solution is to take down the feeders at night or suspend the feeder on a wire between two trees. See NebGuide (G1822, *Managing Deer Damage in Nebraska*, (www.ianrpubs.unl.edu/sendIt/g1822.pdf))

Cats

Domestic and feral cats will try to ambush ground-feeding birds or leap at birds that are not far off the ground. Cats can jump up to 6 feet; therefore, placing feeders far from concealing shrubbery and high off the ground will help keep cats from killing birds. Also, it is best to keep cats from killing any wildlife by keeping cats indoors and having your local Wildlife Control Officer catch and permanently remove feral cats. Consult NebGuide EC1781, *Feral Cats and Their Management*, (www.ianrpubs.unl.edu/sendIt/ec1781.pdf) for more information.

Dogs

Dogs are not usually a predation issue for birds because they are not lay-and-wait predators. However, some dogs, especially sight hounds, will chase birds and disrupt feeding patterns. If this is a problem, you might consider timing your dog's time in the yard with times when some species are less active.

Dogs are notorious squirrel chasers. Most dogs are too slow to catch squirrels; however, some do get rather adept at it. If your dog is a squirrel chaser and is likely to catch squirrels, be sure to monitor the situation. Squirrel bites can cause considerable harm to dogs and if there is a potential for this problem, you may need to make some changes to reduce the likelihood that your dog will catch squirrels. Some dogs will also eat suet or even birdseed if given the opportunity — again, monitor your situation and make changes as necessary.

Summary

Protecting bird feeders is as much an art as it is a science. Keep watching your feeders, as some techniques that are successful today may fail tomorrow. Persistence and a willingness to try additional techniques are essential for ultimate success.

Resources

Backyard Wildlife: Feeding Birds, G2003 (www.ianrpubs.unl.edu/sendIt/g2003.pdf)

Controlling Rats, G1737 (www.ianrpubs.unl.edu/sendIt/g1737.pdf)

Controlling Vole Damage, G887 (www.ianrpubs.unl.edu/sendIt/g887.pdf)

Dealing with Skunks, G1769 (www.ianrpubs.unl.edu/sendIt/g1769.pdf)

A variety of wildlife management publications can be found at www.ianrpubs.unl.edu/epublic/pages/index.jsp?what=subjectAreasD&subjectAreasId=38 or icwdm.org.

The authors welcome your comments and ideas. Please contact Lisa Pennisi at lpennisi2@unl.edu or Stephen Vantassel at svantassel2@unl.edu.

This publication has been peer reviewed.

UNL Extension publications are available online at <http://extension.unl.edu/publications>.